



Connect with Confidence

MultiView

NEC 600

Receiver

Quick Reference
&
Setup Guide



Magenta Research

128 Litchfield Road, New Milford, CT 06776 USA
(860) 210-0546 FAX (860) 210-1758
www.magenta-research.com

MAGENTA MULTIVIEW™ SERIES

© 1998-2009 by Magenta Research All rights reserved.

Magenta Research
128 Litchfield Road
New Milford, CT 06776 USA

This document and the Magenta Research products to which it relates, and the copyright in each, is the property of Magenta Research. Neither the document nor the products may be reproduced by any means, in whole or in part, without the prior written permission of Magenta Research. Magenta Research makes no warranty or representation, either express or implied, with respect to this software or documentation, including their quality, performance, merchantability, or fitness for a particular purpose. As a result, this software or documentation are licensed "as is" and you, the licensee, are assuming the entire risk as to their quality and performance.

In no event will Magenta Research be liable for direct, indirect, special, incidental, or consequential damages arising out of the use of or inability to use the software or documentation.

*Magenta Research and the Magenta Research logo are trademarks of Magenta Research.
All other brands, product names, and trademarks are the property of their respective owners.*

FEDERAL COMMUNICATIONS COMMISSION AND INDUSTRY CANADA RADIO FREQUENCY INTERFERENCE STATEMENTS

This equipment generates, uses, and can radiate radio-frequency energy, and if not installed and used properly, that is, in strict accordance with the manufacturer's instructions, may cause interference to radio communication. It has been tested and found to comply with the limits for a Class A computing device in accordance with the specifications in Subpart B of Part 15 of FCC rules, which are designed to provide reasonable protection against such interference when the equipment is operated in a commercial environment. Operation of this equipment in a residential area is likely to cause interference, in which case the user at his own expense will be required to take whatever measures may be necessary to correct the interference.

Changes or modifications not expressly approved by the party responsible for compliance could void the user's authority to operate the equipment.

This digital apparatus does not exceed the Class A limits for radio noise emission from digital apparatus set out in the Radio Interference Regulation of Industry Canada.

EUROPEAN UNION DECLARATION OF CONFORMITY

The manufacturer declares that this product meets the requirements of EU Directive 89/336/EEC.



Contents

Chapter	Page
1. Specifications.....	2
2. Introduction	3
2.1 Overview.....	3
2.3 Compatible Cabling	3
3. Setup and Installation.....	4
3.1 Cabling Considerations.....	4
3.2 Making the Connections.....	4
3.2.1 Connections and Setup in General	4
3.3 Video Adjustment.....	6
4. Troubleshooting.....	8
4.1 Common Problems	8
Appendix A. Cabling Pinouts.....	10
Appendix B. Sync Mode.....	11
Appendix C. SAP Address.....	12
Appendix D. Rotary Knob menu.....	13

1. Specifications

Cable Required: Category 5, 5e, 6 shielded or unshielded twisted pair

Compliance: CE; FCC Class A, IC Class A

Video Support: all supported VESA modes to WUXGA (1920x1200), RGBHV, HDTV modes including 1080p, 1080i, 720p
(Note: The NEC 600 does not support component, composite or S-video video signals)

Resolution and

Refresh Rate: At 600 ft. (183 m) or less: a maximum of 1920x1200

Required Source

Impedance: Video OUT: 75 ohms;
Audio models: Audio OUT (if any): 600 ohms maximum

Required Destination

Impedance: Video IN: 75 ohms;
Audio models: Audio IN (if any): 600 ohms minimum

Audio

Characteristics: Full Stereo
Line Level 600 Ohm Unbalanced

Serial

Characteristics: Protocol: Asynchronous; transparent to data format;
3 wire, baud rate of 9600*

Connectors: (2) RJ-45, (1) DB9M (console only, not for SAP use)

Temperature

Tolerance: Operating: 32 to 104°F (0 to 40°C);
Storage: -4 to +140°F (-20 to +60°C)

Humidity

Tolerance: Up to 80% noncondensing

Enclosure: Steel

Power: N/A—power supplied by display.
There are no provisions for external power

Size: 1.6"H x 6.8"W x 11.4"D (4.0 x 17.3 x 28.9 cm)

Weight: 2.2 lb. (1.0 kg)

*The serial baud rate may be changed internally via SAP commands (see SAP communication Protocol User Manual), however it is recommended to use 9600 baud for best performance.

2. Introduction

2.1 Overview

This manual covers the Magenta MultiView™ NEC 600 card slot CAT5 Receiver unit. The NEC 600 is intended for use only in compatible NEC displays that have the card slot feature. All signals are input directly into the display so external cabling or power is not required.

The NEC 600 card slot receiver supports video, stereo audio and the SAP pollable RS232 option on a single CAT5 cable. ***In order to support all signals a compatible SAP series transmitter must be used.***

If video only is all that is necessary, any MultiView series transmitter may be used.

The NEC 600 can be controlled and configured via the SAP protocol from a SAP enabled transmitter.

For information on the usage of the SAP protocol, please refer to the ***SAP Communication Protocol*** user manual.

A CAT5 output is included for daisy chaining.

An external DB9 connector is used for console access to the receiver and is not intended for RS232 serial communication from a transmitter unit.

The NEC 600 receiver also features integrated skew compensation.

For information on the respective transmitter unit, please refer to the appropriate manual included with the transmitter.

WARNING

This equipment is not intended for, nor does it support, distribution through an Ethernet network. Do not connect these devices to any sort of networking or telecommunications equipment!

2.2 Compatible Cabling

CAT5 cabling for the MultiView™ Series must be pinned to the T568B wiring specification (see appendix A). We also highly recommend that all CAT5 cables be pre-terminated and tested. Cables terminated on-site or in an existing infrastructure should be tested before use to ensure compliance with the T568B specification. Using incorrectly terminated CAT5 cables can damage the Magenta MultiView™ Series.

Magenta Research products are compatible with CAT5/5e/6 data cabling as well as skew free CAT5/5e cabling manufactured for video applications. Note that some skew free CAT5 is specific to a particular vendor and is not compatible with our products. Please ensure any skew free CAT5 cable is non-proprietary prior to purchase/installation.

CAT6 cable, due to the manufacture method, can exhibit much greater skew than standard CAT5/5e and may require skew compensation beyond what the standard product offers. Please contact Magenta Research for assistance.

3. Setup and Installation

3.1 Cabling Considerations

- We recommend mounting and connecting all cabling to the MultiView™ Series components before applying power.
- Make sure that the CAT5 cable you intend to use has been tested to comply with the T568B wiring specification (See **Appendix A**).

3.2 Making the Connections

3.2.1 CONNECTIONS AND SETUP IN GENERAL

This section contains figures showing connections with the specific MultiView™ Series models. In general, however, the connection and setup procedure at both transmitter and receiver ends is as follows:

At the transmitter end (refer to the transmitter user guide) :

1. Connect the source video to the MultiView™ Series transmitter video input port, which is an HD15 connector labeled SOURCE IN.
2. If desired, attach a local monitor via the local monitor port to LOCAL OUT.
3. Make your audio/serial connections via the 1/8" (3.5mm) audio connector, phoenix , or DB9 serial connector (transmitter model dependent).
4. Connect the CAT5 cable to the transmitter.
5. Apply power on the transmitter. The LED should light and, if there's a local monitor attached, a video image should appear on the monitor's screen.

*At the receiver end (**Ensure display is powered off and disconnected from AC power**):*

1. Remove the left handle on the display and then remove the top option slot blank cover.
2. Insert the NEC 600 receiver into the NEC display slot and secure with the 2 screws that secured the blank cover removed in step 1 and replace the handle.
3. Connect the CAT5 cable to the UTP INPUT connection.
4. Connect the AC power and turn display on (Note that the NEC display only recognizes card slot options only from a cold start (i.e. when the AC power is first connected and the display powered on, not in standby mode).
5. To adjust video levels see **Section 3.3**.
6. To set the SAP address for SAP serial transmission, use the two rotary knobs. See Appendix C and reference the SAP Communication Protocol user manual.

3.2.2 CONNECTIONS ON THE NEC600 RECEIVER

Below the NEC 600 connections are detailed:

Figure 3-1. Connections on the MultiView NEC 600.

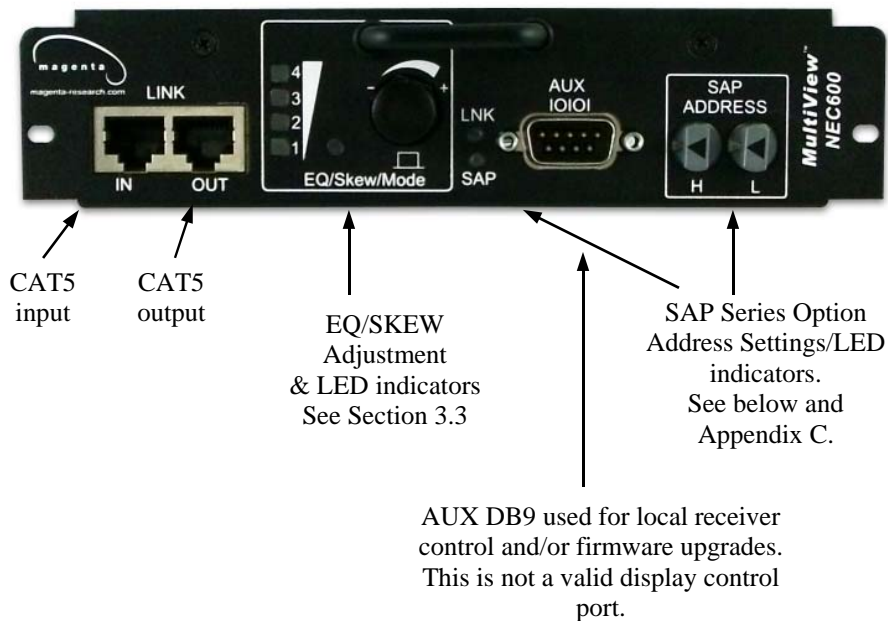

The NEC 600 card slot receiver does not have any internal jumper or switch settings for configuration. Any configuration parameters are changed via the SAP protocol (See the SAP Communication protocol user manual for information). Sync modes may be changed via the EQ/Skew/Mode knob. See Appendix B.

In order to set the NEC 600 receiver SAP address for addressable RS232 usage, use the two rotary knobs labeled "SAP Address". See Appendix C for address information. The SAP and LNK LED indicators can be used to check SAP connectivity per the following :

- LNK Status LED:
 - Glowing dim: Valid connection to SAP transmitter.
 - On: SAP session is active.
- SAP Status LED:
 - Red Pulse: Transmit data activity (to TX unit).
 - Green Pulse: Receive data activity (from TX unit).

MAGENTA MULTIVIEW™ SERIES

3.3 Video Adjustment

3.3.1 Cable Distance Compensation Settings

In order to get the highest quality video signals from your MultiView CAT5 Video System, please follow the instructions and diagrams below:

An Image Adjustment Utility is available for download from:

[http:// www.magenta-research.com/test](http://www.magenta-research.com/test)

Simply open in any image browser on a computer.

If the image file can not be downloaded, use a utility to draw a black box on a white background.

NOTE: TURN KNOB SLOWLY DURING ADJUSTMENT PROCEDURE. Turning too fast may result in missing the proper EQ setting resulting in picture loss.

To Reset EQ and Skew values to 0, remove AC power from the display, push and hold EQ/Skew Knob in and re-apply power to the display.

1. Push EQ/Skew knob in once so that the Mode LED is flashing white.
2. Turn the EQ/Skew knob clockwise until the shadow next to the black box just disappears. The brightness in the white area should be the same as the white area above and below the black box. The 1-4 Range LED's will turn on for indicated cable distances. Starting from zero feet to 600 may take some time. Please continue turning the knob for best picture quality.
3. Press and release EQ/Skew knob until the mode LED is green or wait 10 seconds.

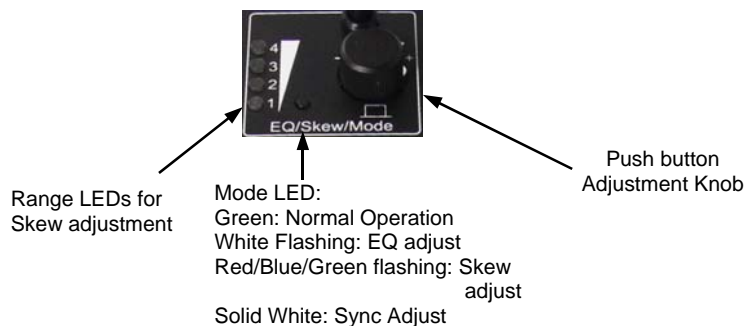

Figure 3-2: Adjustment locations

Distance Compensation Setting Utility

Adjust Cable Compensation control to obtain a minimum shadowing effect in the white area to the right of the black window

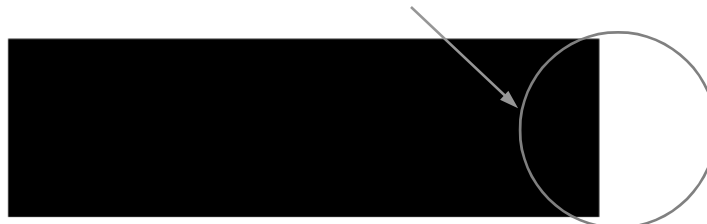

Figure 3-3: Image Adjustment Utility—Cable Length EQ

3.3.2 Skew Compensation Settings

The NEC 600 receiver features integrated skew compensation to adjust for signal timing differences due to differing pair lengths within the CAT5 cable. Using the delay signals, skew may be compensated from 2 to 65 nanoseconds in 2 nanosecond increments on each individual color pair.

An image file is available to assist in these settings. See Figure 3-4 for an example.

1. To adjust individual colors, press the EQ/Skew knob until the desired color Mode LED is flashing. The LED color corresponds to the color channel being adjusted.
2. Using the image utility, turn knob to add/subtract delay timing until a single vertically aligned line of red, green, blue is obtained.
3. When complete press EQ/Skew knob until the Mode LED is green or wait 10 seconds .

Not all colors will have the same delay settings.

Cable Skew Compensation Setting Utility

Adjust skew equalizer to align Red, Green and Blue lines so they are stacked one on top of the other. Next, check white and black lines. Make fine adjustments until there is a minimum of color fringing.

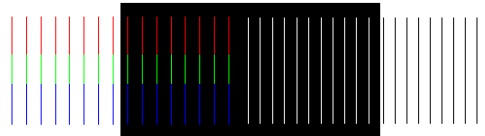

Figure 3-4: Image Adjustment Utility—Skew

4. Troubleshooting

4.1. Common Problems

In most cases, nearly every issue with the MultiView CAT5 Video System can be resolved by checking the CAT5 termination and making sure that it's pinned to the TIA/EIA 568B wiring specification. However, there may be other problems that cause the system to not perform as it's designed. Below are solutions to the most common installation errors.

- Problem:** No video signal at the transmitter local port or at the receiver.
Solution:
- Check that both units are powered.
 - Ensure EQ adjustment is set correctly — turn knob slowly.
 - Make sure the CAT5 cable is terminated correctly per the TIA/EIA 568B wiring specification.
 - Is the display device powered on and functioning? Check to ensure display settings (resolution, refresh rate, etc) are compatible with input signal.
 - The NEC 600 only supports RGBHV video modes. Component, composite or S-video is not supported. This is due to the design on the option card slot interface and not the NEC 600 receiver.
- Problem:** Poor video quality:
Solution:
- Have all receiver adjustments been finished (see section 3.3).
 - Ensure EQ adjustment is set correctly — turn knob slowly.
 - Check all cable connections.
 - The video signal's refresh rate may be set too high. Reset to a lower refresh rate in your monitor-configuration menu.
 - There may be a delay skew issue. See Section on Skew.
- Problem:** Poor audio quality:
Solution:
- Powered speakers are required. Make sure speaker power is ON.
 - Check input source levels from the source device. Make sure the audio source is not overdriven or underdriven.
- Problem:** Serial communication doesn't work correctly.
Solution:
- Are the serial devices connected properly? Are the serial parameters correct for source/destination devices?
 - SAP units have a default baud rate of 9600 bps and use 3 wire (TX,RX,GND) signals only.
 - Please refer to the SAP Communication Protocol user manual for information on using SAP series commands.

Problem:

“Green shift” or “green washout” on multimedia signals.

Solution:

The standard video/serial model is designed to function with DC coupled signals in which the black level is referenced to 0 volts. Nearly all VGA cards function this way.

Some media servers, however, provide AC coupled signals and can cause a green color shift in the video. This is a result of the sync clamping on the red and blue channels of the video/serial model.

For five-component (RGB/H&V) AC coupled video, the MultiView CAT5 XRTx Universal transmitter has been designed with full DC restoration capability. This problem is easily solved via a simple switch setting in the XRTx Transmitter. Please refer to the XRTx Transmitter user manual.

Problem:

Image has purple/blue tint

Solution:

Display gain may need adjustment. Older displays may have an incorrect gain adjustment setting. This requires using the remote to access the “expert mode” . Please contact NEC technical support or Magenta Research for assistance in this.

Displays purchased after May 2009 should not require this.

Problem:

Notes on Daisy Chaining:

Solution:

When daisy chaining, the maximum cable distance is not increased beyond the rated distance of the receiver used. For example, an AK600 can only daisy chain within 600 ft of the transmitter. It is possible to daisy chain out of a short range receiver into a longer range receiver to increase the range. For example, over 600 ft an AK600 can be daisy chained into an AK1200 which allows for daisy chaining to 1,200 ft.

- When using NEC600 SAP units, a maximum of 10 units may be daisy chained within the rated cable length of the receiver if using standard CAT5/6 or a maximum of 7 units may be daisy chained within the rated cable length of the receiver if using skew-free cable.
- Note that if SA/SAP units are used for video only and the SA/SAP option is **not** in use, then you may daisy chain to 12 units.

Appendix A. Cabling Pinouts

Table A-1. T568B CAT5 pinout

T568B CAT5 Specification

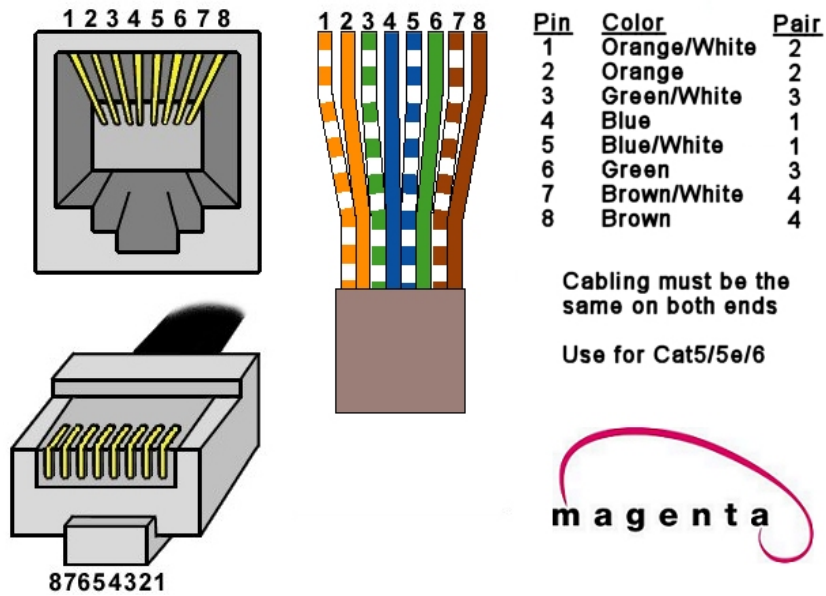

NOTE: The external DB9 connector is intended for console access to the receiver and does not support external SAP RS232 protocol. This connection should not be used to control the display.

Appendix B. Setting Sync Mode

The NEC 600 has the capability for fixed and agile sync. The default sync mode setting is for agile sync which replicates the source sync polarity signals. However some displays require a fixed sync polarity that is not possible to change at the video source. 1080P signals may also require this mode if the sync is a very narrow pulse.

The following details how to change the sync polarity of the horizontal and vertical sync signal. This is only valid if sync mode is set to FIXED (**Note that the transmitter must also be set to the same sync mode—see transmitter user manual. Not all transmitters support this feature.**)

To enter Sync Configuration mode, press and hold the EQ/Skew knob for 5 seconds until the Mode LED turns solid white (not flashing).

The Range LEDs (1-4) will indicate which parameter is selected and its current value. To change a value, turn the knob. To select the next parameter, press the knob. To exit, press knob until Mode LED turns green or wait 10 seconds.

LED 1: Dim green = Agile Sync (default)
Bright Green = Fixed Sync

LED 2: Dim Green = Negative Horizontal sync polarity
Bright Green = Positive Horizontal sync polarity

LED 3: Dim Green = Negative Vertical sync polarity
Bright Green = Positive Vertical sync polarity

In normal operation, the Range LED's also indicate which sync mode is in use:

LED1: Off indicates Agile, non-fixed sync mode (default)
On indicates Fixed sync mode in use.

LED2: On indicates Positive Horizontal sync polarity if fixed sync is enabled.
Off indicates Negative Horizontal sync polarity if fixed sync is enabled.

LED3: On indicates Positive Vertical sync polarity if fixed sync is enabled.
Off indicates Negative Vertical sync polarity if fixed sync is enabled.

NOTE: When in Sync Configuration mode, pressing the knob past LED3 will result in all LED's being off. This is a special video voltage offset mode that is currently not implemented. It is important that the knob not be turned when in this mode as you could change the video voltage level and affect picture quality. If this does happen, please turn the knob fully counterclockwise to restore the video voltage level to its default state.

Appendix C. SAP Addressing

To set the NEC600 SAP address, use the two rotary address knobs on the unit. You will need to convert the decimal address desired to a hexadecimal address using the table to the right.

The left knob designated H is the most significant digit, while the right side designated L is the least significant digit.

For example, to set a decimal address of 90, the knobs should be set to H=5 and L=A, for a hexadecimal number of 5A.

Please refer to the **SAP Communication Protocol** User Guide for information on usage of the SAP series commands.

Dec	Hex	Dec	Hex	Dec	Hex	Dec	Hex
00	00	64	40	128	80	192	C0
01	01	65	41	129	81	193	C1
02	02	66	42	130	82	194	C2
03	03	67	43	131	83	195	C3
04	04	68	44	132	84	196	C4
05	05	69	45	133	85	197	C5
06	06	70	46	134	86	198	C6
07	07	71	47	135	87	199	C7
08	08	72	48	136	88	200	C8
09	09	73	49	137	89	201	C9
10	0A	74	4A	138	8A	202	CA
11	0B	75	4B	139	8B	203	CB
12	0C	76	4C	140	8C	204	CC
13	0D	77	4D	141	8D	205	CD
14	0E	78	4E	142	8E	206	CE
15	0F	79	4F	143	8F	207	CF
16	10	80	50	144	90	208	D0
17	11	81	51	145	91	209	D1
18	12	82	52	146	92	210	D2
19	13	83	53	147	93	211	D3
20	14	84	54	148	94	212	D4
21	15	85	55	149	95	213	D5
22	16	86	56	150	96	214	D6
23	17	87	57	151	97	215	D7
24	18	88	58	152	98	216	D8
25	19	89	59	153	99	217	D9
26	1A	90	5A	154	9A	218	DA
27	1B	91	5B	155	9B	219	DB
28	1C	92	5C	156	9C	220	DC
29	1D	93	5D	157	9D	221	DD
30	1E	94	5E	158	9E	222	DE
31	1F	95	5F	159	9F	223	DF
32	20	96	60	160	A0	224	E0
33	21	97	61	161	A1	225	E1
34	22	98	62	162	A2	226	E2
35	23	99	63	163	A3	227	E3
36	24	100	64	164	A4	228	E4
37	25	101	65	165	A5	229	E5
38	26	102	66	166	A6	230	E6
39	27	103	67	167	A7	231	E7
40	28	104	68	168	A8	232	E8
41	29	105	69	169	A9	233	E9
42	2A	106	6A	170	AA	234	EA
43	2B	107	6B	171	AB	235	EB
44	2C	108	6C	172	AC	236	EC
45	2D	109	6D	173	AD	237	ED
46	2E	110	6E	174	AE	238	EE
47	2F	111	6F	175	AF	239	EF
48	30	112	70	176	B0	240	F0
49	31	113	71	177	B1	241	F1
50	32	114	72	178	B2	242	F2
51	33	115	73	179	B3	243	F3
52	34	116	74	180	B4	244	F4
53	35	117	75	181	B5	245	F5
54	36	118	76	182	B6	246	F6
55	37	119	77	183	B7	247	F7
56	38	120	78	184	B8	248	F8
57	39	121	79	185	B9	249	F9
58	3A	122	7A	186	BA	250	FA
59	3B	123	7B	187	BB	251	FB
60	3C	124	7C	188	BC	252	FC
61	3D	125	7D	189	BD	253	FD
62	3E	126	7E	190	BE	254	FE
63	3F	127	7F	191	BF	255	FF

Appendix D. Rotary Knob Menu

The following diagram details the various configuration settings available through the rotary knob. This is provided to graphically show each menu choice.

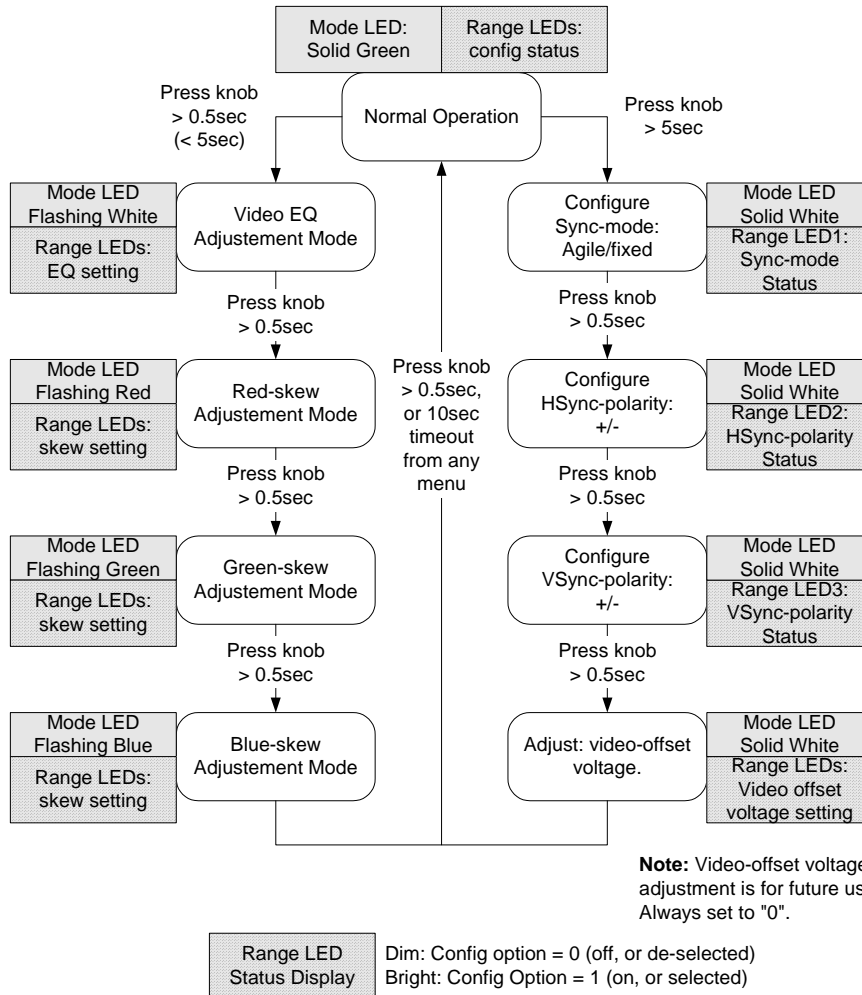



Magenta Research

128 Litchfield Road, New Milford, CT 06776 USA
(860) 210-0546 FAX (860) 210-1758
www.magenta-research.com

PN 5310229-01, Rev 01, Jul-2009

